

This camera manual library is for reference and historical purposes, all rights reserved.

This page is copyright by mike@butkus.org M. Butkus, N.J.

**This page may not be sold or distributed without the expressed
permission of the producer**

I have no connection with any camera company

If you find this manual useful, how about a donation of \$3 to: M. Butkus, 29 Lake Ave., High Bridge, NJ 08829-1701 and send your E-mail address too so I can thank you. Most other places would charge you \$7.50 for a electronic copy or \$18.00 for a hard to read Xerox copy. These donations allow me to continue to buy new manuals and maintain these pages. It'll make you feel better, won't it?

If you use Pay Pal, use the link below. Use the above address for a check, M.O. or cash. Use the E-mail of butkusmi@ptd.net for PayPal.



[back to my "Orphancameras" manuals /flash and light meter site](#)

Only one "donation" needed per manual, not per multiple section of a manual !

The large manuals are split only for easy download size.

EXAKTA

Varex IIa

1½ x 1 in.

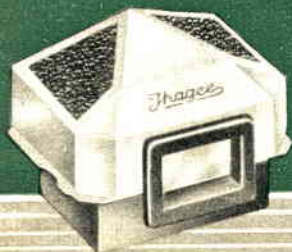

- 18 = film-speed indicator
- 19 = control disc for film transport
- 19a = removable axle of camera-back hinge
- 20 = "M" flashbulb contact
- 21 = red mark on camera body (important when changing lenses)
- 22 = depth of field scale
- 23 = distance setting ring
- 24 = diaphragm ring
- 24b = winding lever for the automatic pre-setting device
- 24c = release knob for the automatic pre-setting device
- 25 = lens
- 26 = red mark on lens (to match 21 when changing lenses)
- 27 = lens bayonet catch
- 28 = "F" flash bulb contact
- 29 = take-up spool for exposed film
- 30 = film chamber for take-up spool or cart .
- 31 = film transport sprockets
- 31a = cartridge holder
- 32 = film guides
- 33 = film gate
- 34 = knife for cutting exposed film
- 35 = handle of knife
- 36 = fork of film rewinding knob
- 37 = film rewinding knob
- 38 = centre part of film rewinding knob (push in before rewinding!)
- 39 = film chamber for feeder cartridge (unexposed film)
- 40 = hinged camera-back (removable)
- 41 = film pressure plate
- 42 = tripod socket
- 43 = Penta Prism
- 44 = ocular of Penta Prism

Instructions
for using
the

EXAKTA

Varex IIa

1½ x 1 in

24x36mm

Contents

	Page
A. Opening and closing the camera back.....	5
B. Opening and closing the Finder Hood.....	6
C. Shutter and film transport.....	7
D. The lens, and how to focus.....	13
E. How to use and exchange the Finder Hood.....	18
F. How to use and exchange the Penta Prism	22
G. How to load the EXAKTA Varex.....	25
H. Changing the film	29
J. Flash technique	33
K. EXAKTA Varex accessories.....	38
L. Careful handling of camera and lens.....	59

There may be slight deviations between the camera models and the illustrations in this booklet.

The EXAKTA Varex IIa 1 1/2x1 in. (24x36 mm) marks the increasing progress in the development of our well-known Kine-Exakta, the first 35 mm single-lens reflex camera.

This camera introduced ground glass focussing so highly esteemed by beginners and experts alike, into miniature photography, using, however, **one lens only** which produces first the reflex image and then the final picture. The EXAKTA Varex, too, is built on the basic principle of the **single lens reflex**: In its interior there is a small movable mirror which reflects the picture formed by the taking lens on the reflex focussing screen up to the moment of releasing the shutter. This alone makes it possible for the reflex image to be absolutely in accordance with the final photo. The EXAKTA Varex is free from parallax error and you will always be able to rely on the ground-glass image for picture combination and critical focussing. The Kine-Exakta, though a very versatile camera, is, in this respect, highly surpassed by the Two-System EXAKTA Varex: The alternative focussing systems (Reflex Finder Hood or Penta Prism) permit utilising all the advantages of the single-lens reflex camera as well as those of the camera with direct vision range finder, ensuring full success, thanks to their adaptability to the given tasks. The EXAKTA Varex is a high-class precision camera and can only meet all requirements if it is correctly operated from the first. **Before working practically, please study the instructions for using your new camera!** You will be rendering yourself the best service in doing so, for you will avoid wrong handling right from the beginning as well as difficulties with the camera mechanism.

We are delighted that you have chosen the EXAKTA Varex, and we wish you every success with your camera. Please remain in good contact with your photodealer, that he may keep you well informed regarding all novelties coming from our factory. It goes without saying that we ourselves will always be at your disposal, should you be in need of our help or advice in special problems concerning the EXAKTA Varex.

I H A G E E C A M E R A W O R K S A K T I E N G E S E L L S C H A F T . D R E S D E N A 1 6

44 important camera parts

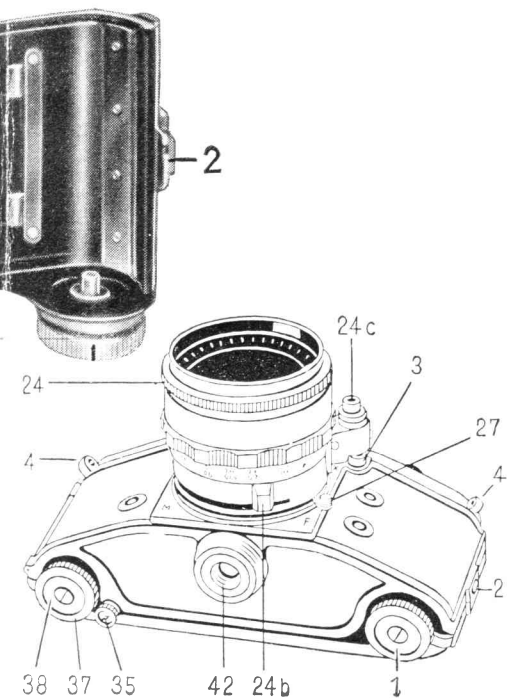

- 1 = button for opening camera-back (see also Fig. 4)
- 2 = camera-back lock (operated by button No. 1)
- 3 = shutter release knob
- 3a = hinged shutter release lock
- 4 = neck-strap eyelets
- 5 = exposure counter
- 5a = knob for setting exposure counter
- 6 = film transport and shutter winding lever
- 7 = rewinding stud
- 8 = speed-setting knob for $\frac{1}{25}$ – $\frac{1}{1000}$ sec., "T" and "B"
- 9 = catch for Finder Hood and Penta Prism
- 10 = "X" electronic flash contact
- 11 = Reflex Finder Hood
- 12 = cover to protect hinged focussing magnifier
- 13 = focussing magnifier (folded down)
- 14 = release button for No. 13
- 15 = rear flap of Finder Hood with frame-finder eye-piece
- 16 = Finder Hood catch
- 17 = speed-setting knob $\frac{1}{5}$ –12 sec., and $\frac{1}{5}$ –6 sec. with delayed action

Fig. 3

Before loading the EXAKTA Varex with a film,

Fig. 4

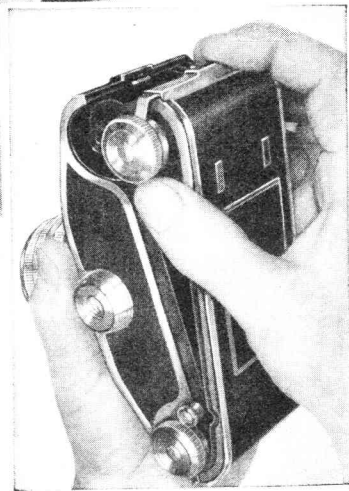
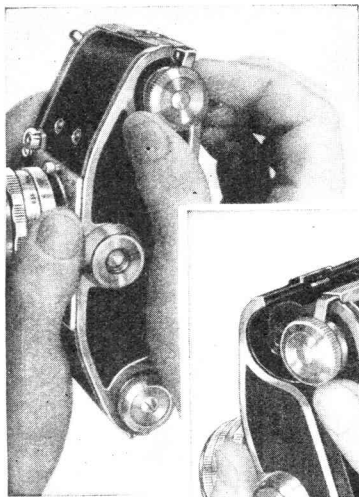

begin by getting thoroughly acquainted with the unloaded camera. Train yourself to master the shutter controls, opening and closing the camera, composing and critically focussing the picture with the Finder Hood as well as with the Penta Prism. When doing so, handle the camera as though it were loaded. Not until you have achieved a complete mastering of the camera, should you load it with a film. It is advisable to start by using an old film, even an exposed one.

Fig. 5

A. Opening and closing the camera back

Hold the camera (Fig. 4) with your left hand. Pull out the button (1) with your right hand and fix it by a short turn either to the left or to the right. Pull away the hinged camera back (40) from the camera body with your right index finger on the lock of the camera back (2) (Fig. 5). The camera back (40) is connected with the body by a hinge. When loading the EXAKTA Varex be careful not to press the dangling camera back against your body, otherwise the hinge may be damaged, so that the camera back (40) could not be shut properly, thus causing penetration of straylight. When closing the camera back (40) take care that it engages correctly in the groove on the camera body. Press the camera back (40) slightly against the camera body. Turn the button (1) to the left or right, until it snaps into position. The camera back is now bolted safely.

The camera back can also be removed from the camera, if so desired. After having opened the camera back, pull out the removable hinge pin (19a, Fig. 1; see also Fig. 6). In this respect, too, the EXAKTA Varex meets all personal requirements. When the separated back is attached to the camera and closed, take care that the grooves of the back and the body are linked together. If the camera back is to be fastened firmly to the camera again, carefully insert the pin into the hinge, as shown in figure 6.

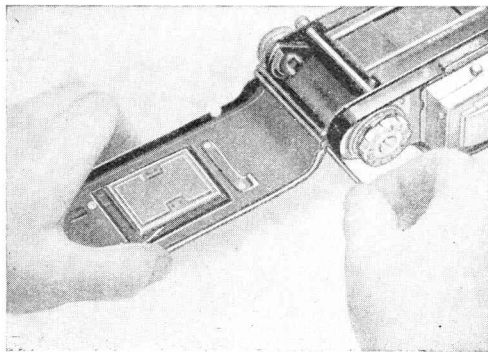

Fig. 6

B. Opening and closing the Finder Hood

Pressure on the catch (16) automatically opens the Finder Hood (11) (Fig. 7). You will find a detailed description of its employment and the various possibilities for observing the image in section E (page 18). Here are just the most important features: The ground glass image is always precisely the same as the future photograph. Therefore, the ground glass image is the decisive factor for all operations that lead to taking the picture: composition, choice of frame, critical focussing, setting the diaphragm; even the degree of brightness of the ground glass image permits determining the exposure time fairly accurately. — If there is no image visible in the Finder Hood, the film transport lever (6) has to be wound once, clockwise, as far as it will go (Fig. 8). Do not let the lever, spring back suddenly but soften the retrograde movement with your left thumb.

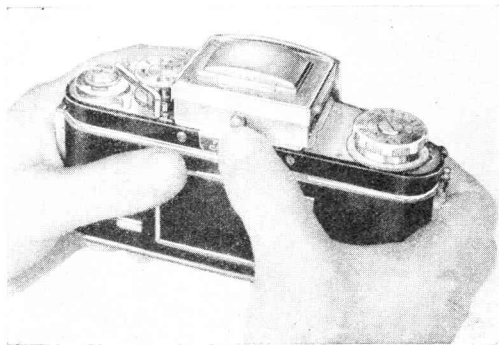

Fig. 7

Attention! Film transporting and shutter winding are completely in order if the film transport lever (6) automatically moves back into position. **On no account should the film transport lever (6) be forced back at any intermediate position**, otherwise the mechanism will be damaged. Besides, it is impossible to release the shutter, even if the release knob (3) has been unlocked, at any inbetween stage of the film transport lever (6), see page 8. This is a reliable protection against partial double exposures in

Fig. 8

consequence of incomplete film transporting. Before closing the Finder Hood (11) make sure that the additional focussing magnifier (13) is in its basic position (Section E). Fold the two side flaps of the Finder Hood inwards (in either order), then the rear flaps (15), and finally the front section until it snaps into position (Fig. 9).

C. Shutter and film transport

The EXAKTA Varex is fitted with a high precision focal-plane shutter. To study its working, look into the open back of the unloaded camera. Remove the lens (see Section D, page 13), and you will see that, on releasing, the mirror swings up underneath the Finder Hood, so that no stray light may penetrate into the interior of the camera. The ground glass image, therefore, is not visible, unless the shutter has been wound up again, after the exposure.

The focal-plane shutter of the EXAKTA Varex distinguishes itself by its great variety of speeds. The speed-setting knob (8) (Fig. 10) is for the

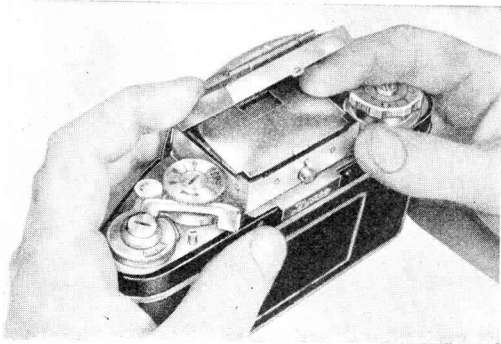
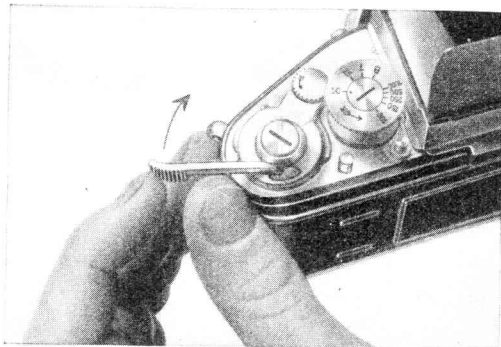
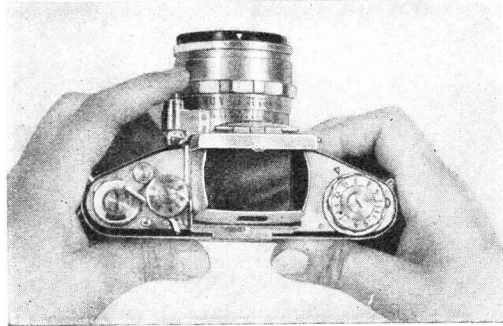
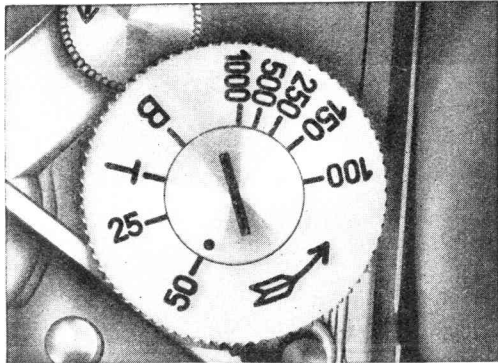

Fig. 9



fast shutter speeds from $\frac{1}{1000}$ to $\frac{1}{25}$ sec. The figures engraved are fractions of seconds, $25 = \frac{1}{25}$, $50 = \frac{1}{50}$ sec., etc. To set the speeds, lift the knob (8) and turn it in the direction of the arrow until the required exposure time is opposite the red mark on the immovable inner disk. Then let the knob (8) spring back into its original position. In the same way, set the focal plane shutter for time exposures longer than 12 sec. B or T. Releasing (Fig. 11) is performed by pressing the release knob (3), into which a cable release can also be screwed. The release knob may be protected against unintentional tripping by the hinged shutter release lock (3a) (important for transporting as well as for storing the camera). To free the release knob for exposing swing up the lock. If the speed knob (8) is set on B, the shutter opens upon pressure on the release knob (3), remains open as long as the knob is pressed, and closes again as soon as pressure is relaxed. If the speed knob (8) is set on T, the shutter opens by pressure on the

Fig. 11

release knob (3) and remains in this position until it is closed again by pressing the release knob (3) a second time. These two settings (B and T) are used — as already said — for time exposures longer than 12 seconds, for the speed mechanism of the EXAKTA Varex allows for exposure times up to 12 seconds automatically (see below!). Longer exposure times may be measured by counting the seconds, or with a watch. In this case it is absolutely necessary to use a tripod (tripod socket (42) on camera base) or to place the camera on a sturdy support (a table, a wall, etc.). For all instantaneous exposures from $1/25$ to $1/1000$ sec. the camera may be held in the hand.

The speed-setting knob (17) (Fig. 12) controls the exposure times longer than $1/25$ sec. The fractions of seconds (e. g. $1/5$ sec.) are indicated on this slow speed knob (17) as fractional numbers, while all the whole numbers mean full seconds (e. g. 1=1 sec., 2=2 secs., etc.). The black figures are for exposures immediately on release of the focal shutter. The red marks, however, signify that the shutter runs down about 13 seconds after releasing, the self-timer, in the meantime, permitting the photographer to step into the picture, making it possible to take a photograph of himself. The additional speed regulating mechanism and the self-timer of EXAKTA Varex II a function practically free from noise and have to be operated precisely according to the following instructions:

- a) Set the fast speed knob (8) on the opposite side of the Finder Hood on T or B.

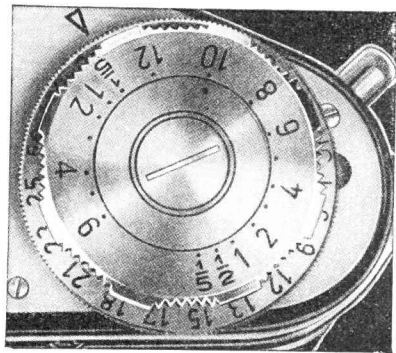

Fig. 12

- b) Before handling the slow speed knob (17), wind the shutter, if necessary, by advancing the film transport lever (6) as far as it will go. Then turn the slow speed knob (17) firmly clockwise as far as the stop, and the speed regulating mechanism is wound up. If your last exposure was made at a short speed (e. g. $\frac{1}{5}$ sec.), the mechanism has run down a little way only, which, however, should not irritate you, but in any case the resistance is to overcome, which is caused from an additional spring and this short piece must be rewound vigorously as far as it will go.
- c) After this, lift the outer ring of the slow speed knob (17), turn the ring until the desired speed stands opposite the red mark on the middle ring, and let the outer ring of the knob (17) snap into position again.
- d) Black figures = immediate exposure,
red figures = exposure with 13 seconds delay (self-timer).

Should you intend using one of the slow speeds, $\frac{1}{25}$ to $\frac{1}{1000}$ sec., in connection with the self-timer (= delayed action release), work as follows (shutter must be wound up):

- a) Set fast speed knob (8) on the desired number (e. g. $\frac{1}{25}$ sec.).
- b) Turn slow speed knob (17) as far as it will go and set it on any one of the red figures.

After releasing, 13 seconds will elapse, whereupon the exposure takes place at the speed set on the knob (8). The speed-regulating mechanism and the self-timer function – as mentioned above – practically free from noise. We strongly advise every EXAKTA Varex owner to practise operating the shutter until he is perfectly acquainted with all details. To facilitate handling the shutter, we repeat concisely the phases as follows:

Instantaneous exposures from $1/25$ to $1/1000$ sec.

Lift fast speed knob (8), turn it in the direction of the arrow, let it snap back into position when exposure time and red mark are opposite each other.

Long exposure times (T and B)

Lift fast speed knob (8), turn in the direction of the arrow, let it snap into position when the T or B stands opposite the red mark.

B = shutter remains open only as long as shutter release knob (3) is being pressed.

T = shutter opens by pressure on the release knob (3) and closes on second pressure.

Longer instant exposures and shorter time exposures from $1/5$ sec. to 12 secs.

Wind the shutter (= move film transport lever (6) as far as the stop), set fast speed knob (8) on T or B, as described above, turn slow speed knob (17) as far as it will go (= winding up speed regulating mechanism), lift knob (17), turn it until black figure and red mark are opposite each other, let knob (17) snap into position.

Self-timer photos with 13 secs. delayed action, for exposures from $1/5$ sec. to 6 secs.

Wind the shutter, set fast speed knob (8) on T or B, as described above, turn slow speed knob (17) as far as it will go (= winding up speed regulating mechanism), lift knob (17), turn it until red figure and red mark are opposite each other, let knob (17) snap into position.

Self-timer photos with 13 secs. delayed action for exposures from $\frac{1}{25}$ to $\frac{1}{1000}$ sec.

Wind the shutter, set fast speed knob (8) to the required exposure time (e. g. $\frac{1}{50}$ sec.), turn slow speed knob (17) as far as the stop (= winding up speed regulating mechanism), lift knob (17), turn it until any one of the red figures and the red mark are opposite each other, let knob (17) snap into position.

Before each exposure, move film transport lever (6) as far as it will go (refer once more to Section B, paragraphs 1 and 2) (Fig. 8). By this movement the shutter is wound, the film advanced by one frame, and the mirror set so that the reflex image is visible again.

For rapid sequence exposures, it is important that all the speeds of the small fast speed knob (8) are instantly ready for use again as soon as the film transport lever (6) has been advanced. Therefore, the speeds of the knob (8) may be set either before or after winding up the shutter.

Film advance and shutter winder being coupled, double exposure of one section of film in the film gate (33) is normally impossible. If, however, in exceptional cases, two exposures on one frame for certain purposes (pictures of doubles) should be desirable, the shutter alone can be wound up as follows: After the first exposure, turn the small fast speed knob (8) with thumb and index of your left hand in the direction of the arrow without lifting it, until you feel a stop. While winding up the shutter, the knob (8), being under tension tries to snap back again. You must, therefore, while turning, keep the knob (8), under slight pressure.

During intervals between exposures, the release knob (3) may be protected by swinging the release lock (3a) over the knob.

D. The lens, and how to focus

The lens (25) of the EXAKTA Vorex is exchangeable. The camera should always be kept with the lens installed or with the protective cover, which is inserted into the lens bayonet, to avoid penetration of dust. The front element of the lens is protected by a lens cover which, of course, must be taken off before exposing. To remove the lens, press the knob of the bayonet catch (27) towards the lens (Fig. 13). Turn the whole lens to the left (looking at camera front). Two red marks (21 and 26) are now opposite each other, one on the camera body, the other on the lens. Lift the lens out of the camera front. — When inserting the lens, the procedure is reversed: Begin with putting the lens (25) into the bayonet mount (red marks <21 and 26> are opposite each other), turn it to the right until the lens bayonet catch (27) snaps into position.

To obtain critical sharpness turn the distance ring (23) until the main subject appears absolutely sharp on the focussing screen in the Finder Hood (11). Then you will see the lens-to-subject distance on the scale of the distance setting ring (23) opposite the red mark (Fig. 14/15).

By rotating the knurled diaphragm ring (24) the lens aperture is adjusted. Turn the ring to the left or to the right, until the stop required is opposite the red mark. The figures on the ring indicate the effective lens openings, i. e.



Fig. 13



low figures (2, 2,8, 3,5, 4, etc.)
 = large aperture = short exposure time,
 high figures (22, 16, etc.)
 = small aperture = long exposure time.

From one stop to another means double or half the exposure time. Example: If the speed is $1/50$ sec. for an aperture of $f/8$, it will be $1/25$ sec. for $f/11$ or $1/100$ sec. for $f/5,6$. Reduction of the lens aperture (higher figures) produces increase in depth of field: Not only the main subject, but also more of the foreground and the background will be in sharp focus. Further details may be seen from the depth of field scale (22) on the EXAKTA Variox lens mount: On either side of the middle mark there is a diaphragm scale. One side shows the distance from which the sharpness reaches and the other side, up to which distance the image is sharp (= depth of field range). The distance in question stands opposite the selected diaphragm figure. If on one half of the scale the aperture chosen ap-

Fig. 15

pears behind the infinity sign (∞) — proceeding from the middle — the sharpness will extend to infinity. Example (see Fig. 14): Lens set at 4 m, diaphragm stop 8: range of sharpness from about 2,60 to 8 m (using a lens with 5 cm focal length). If employing a lens with 5,8 cm focal length, the depth of field will be somewhat reduced: lens set at 4 m, diaphragm stop 8: range of sharpness from about 2,80 m up to about 7,50 m (see Fig. 15). — All these distances are measured from the film plane of the EXAKTA Varex to the subject. Most lenses of the EXAKTA Varex are provided with a device for "pre-setting the diaphragm". The brightness of the ground glass screen image being considerably diminished when the diaphragm is stopped down, focussing should always be done at full aperture, and the lens stopped down afterwards. But to avoid having to move the camera from the taking level in order to stop down the aperture, the device for the "pre-set diaphragm" has a stop ring (24 a) for the diaphragm (e. g. $f/8$) which can be set in advance. On the majority of lenses, you press back and turn the knurled stop ring (24 a) (Fig. 15) behind the diaphragm ring until the aperture required is opposite the red mark. Then let the knurled ring (24 a) spring back. The diaphragm ring now stops fast at the "pre-set" aperture and may be turned back to this point without visual control after focussing at full aperture. As a logical continuation in the development of the "pre-set diaphragm" several of the EXAKTA Varex lenses have been equipped with the "automatic diaphragm pre-setting device", a great advantage if you consider that releasing the shutter automatically closes down the diaphragm to the pre-selected aperture. The "automatic diaphragm" has to be wound up as shown in Fig. 16: Move the lever underneath the lens to the right (seen in viewing direction). With the lens at full aperture, the spring device clicks in and the lever automatically jumps back to its original position.

The winding-up process may take place:

a) before selecting the diaphragm stop. In this case, the diaphragm is at full aperture and remains

so while the pre-selecting ring (24) is being set. The diaphragm does not close down to the pre-selected stop before the shutter is actually being released;

- b) after selecting the diaphragm stop. In this case, the diaphragm is closed down to the pre-selected aperture but will open the moment the automatic pre-setting device is being wound up, snapping in at the widest aperture.

Picture composition and sharpness have to be adjusted with the lens wide open. On depressing the release knob (24c) belonging to the lens (in front of the shutter release knob (3) on the camera) you

automatically close down the diaphragm to the pre-selected aperture, whereupon the shutter is immediately released.

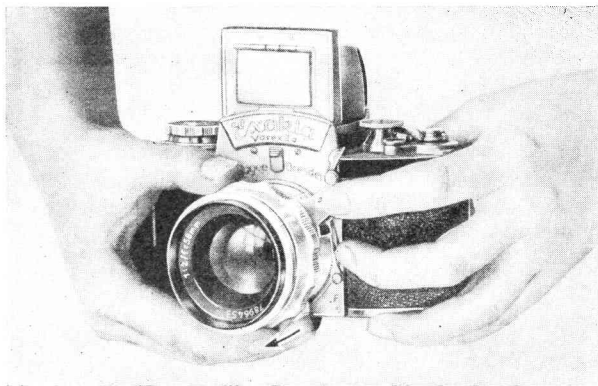

To make sure that the plunger of the lens release (24c) will push the shutter release knob (3) far enough into the camera, you may find it necessary to adjust it to the proper length. This is done by removing the lens from the camera and turning the plunger as required with a screw driver. The lens release knob (24c) is equipped with a thread to accept a wire release.

Fig. 16

Adjustment of the iris diaphragm on these lenses takes place as follows:

Press diaphragm setting ring (24) in the direction of camera body and rotate it until the desired number stands against the red mark. Then let the diaphragm ring (24) jump back to its original position. (The larger apertures permit setting also between two diaphragm numbers — half a stop larger or smaller.) As already mentioned, the "automatic diaphragm", when adjusted, clicks in at the widest aperture, and only at the moment the shutter is being released, the diaphragm springs back to the pre-set stop. As long as the "automatic diaphragm" is not wound up, the diaphragm can, at any time, be set to the desired stop by actuating the setting ring (24), whereupon the reflex image in the EXAKTA Varex will immediately reveal the change in brightness and depth of field.

E. How to use and exchange the Finder Hood

A bright ground glass image is visible in the Finder Hood (11) of the EXAKTA Varex. It is magnified on the ground glass magnifier to such a degree that focussing is possible. For critical focussing, wherever required, the built-in additional magnifier (13) is employed: Move the release button (14) upwards along the guide in the Finder Hood frame (Fig. 17), while exercising slight counter pressure with your thumb. To bring the built-in magnifier back to its original position, proceed conversely: Move button (14) downwards again, gently resisting with your index finger.

The sharp definition of the ground glass image facilitates composition and determination of picture outline. While stopping down the diaphragm, you can even observe the varying extent of the depth of field. Focussing should always be performed at full lens aperture and the diaphragm stopped down afterwards. For

colour film, the reflex image in natural colour shows precisely the effect of the final photo.

Usually, the EXAKTA Varex is held at chest-level (Fig. 18). Illustration 19 shows how to hold the camera when using the built-in magnifier. When viewing at eye-level, vertical pictures at right angles can be taken with the Finder Hood (Fig. 20), enabling the photographer to work unobserved (Fig. 21). The Penta Prism (see Section F) also permits vertical pictures in direct vision showing an upright and laterally correct image. Control of the ground glass image is

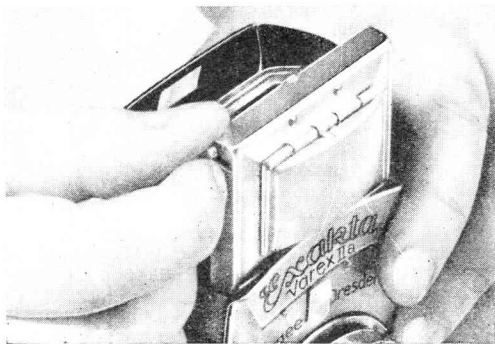

Fig. 17

Fig. 18



Fig. 20



Fig. 19

Fig. 21

possible too, by holding the camera upside down above your head, and looking up into the Finder Hood (Fig. 22). This is the way to take snapshots from behind a wall, over the heads of a crowd, etc. The Finder Hood (11) is also convertible into a frame-finder (Fig. 23): Bring the focussing magnifier (13) into working position by operating the knob (14), swing the protective cover (12) upwards, and look

into the rectangular opening of the rear Finder Hood flap (15) (Fig. 24). The rear frame must be exactly limited by the frame in the front of the Finder Hood, to make sure that the image visible in the frame-finder corresponds to the future photo. This method of working is advisable for sport shots etc. (unless the Penta Prism is used), but not for exposures at shorter distances than about 3 m (10 feet), because of parallax deviation. Just as it is not recommendable to use the frame-finder for wide-angle and Tele-lenses, since the outline of the finder image is valid only for the standard optical equipment. With other lenses, the image is viewed in the Finder Hood only, perfectly free from parallax, and in correct outline.

When changing finders, the Finder Hood (11) must be closed. Depress the Finder Hood catch (9) and lift the closed Finder Hood straight upwards (Fig. 25). When replacing the Finder Hood, insert it carefully in a perpendicular direction and press it down until it snaps in audibly.

Never use force!



Fig. 22

When focussing with the Finder Hood, persons with faulty eyesight may use their spectacles for close-up work or, in many cases, they will be able to focus without their eye-glasses.

Fig. 23

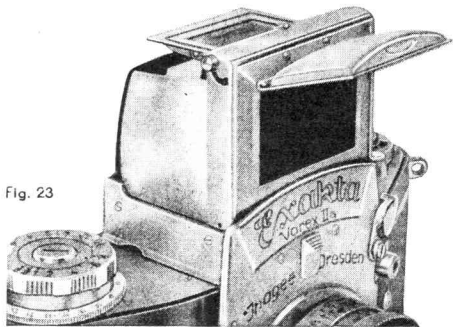

21



Fig. 24

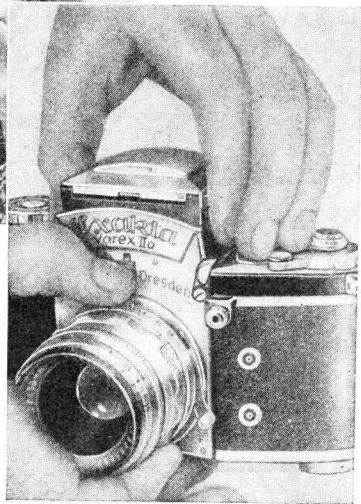

Fig. 25

F. How to use and exchange the Penta Prism



Fig. 26

The EXAKTA Varex is a two-system camera, in which the focussing systems are interchangeable, as the circumstances may require. The preceding Section E, describes how the Finder Hood can be removed and replaced by the Penta Prism (43) (Fig. 27). This Penta Prism (see also Fig. 1), the most important supplementary part of the EXAKTA Varex, is available separately as a camera accessory and is, above all, designed for sports shots, fast moving subjects, press-work, etc. With inserted prism-finder the camera is held at eye-level (Fig. 26) and the object to be photographed viewed directly through the finder. For horizontal pictures, you may also turn the camera upside down and press the back (40) against your forehead, as shown in Fig. 28 (advantage: in this position the camera can be held fast, and the higher optical level facilitates photographing over a crowd or other impediment. Whether vertical or horizontal, the Penta Prism always reveals an upright and laterally correct reflex image, true to nature in all details (Fig. 29). The image in the Penta Prism moves in the same direction as the object. Holding the camera at eye-level, you will easily be able to follow moving subjects. For maximum

Fig. 27

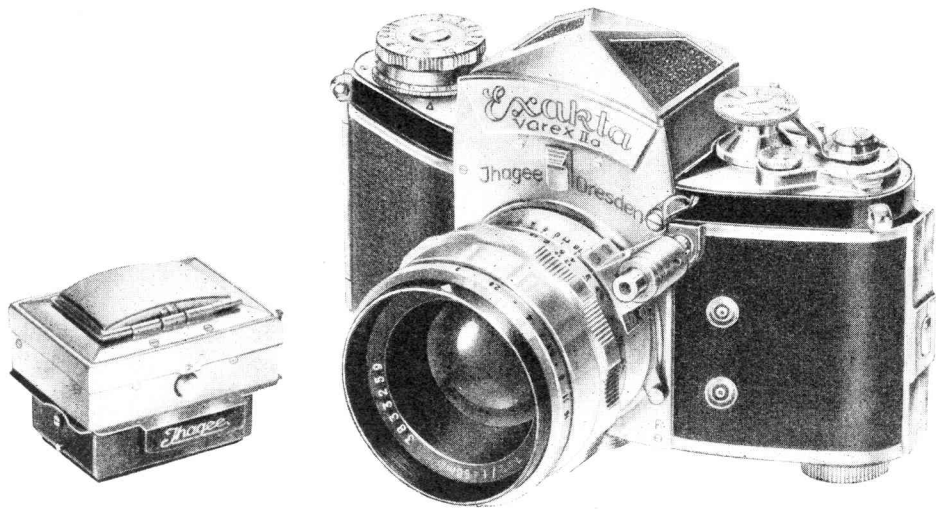

Fig. 28



speed sport movements the thousandth of a second of the focal-plane shutter is not yet short enough, the EXAKTA Varex can, while exposing, move along with the object. That is possible, too, at longer speeds (up to $1/100$ sec.). In this case, the fixed background, it is true, becomes blurred, but the object shows an excellent definition despite quickest movement.

The Penta Prism (43) is installed and removed from the camera in exactly the same way as the Finder Hood (11) (see Section E).

Make sure that the Penta Prism is inserted in its place in a strictly perpendicular direction. Never use force! Persons with faulty eyesight will find it most convenient to wear long-distance spectacles when focussing with the Penta Prism. A view-finder eye-piece, also, is available for the Penta Prism (see page 56) into which a suitable eye-glass can be fitted by an optician, so that critical focussing will be possible without further help.

Fig. 29

Fig. 30

G. How to load the EXAKTA Varex

The EXAKTA Varex takes 35 mm perforated miniature cinefilm for 36 exposures $1\frac{1}{2} \times 1$ in ($= 24 \times 36$ mm) on a strip of the usual length of 5 ft 4 in ($= 1,60$ m). You are at liberty either to use a factory-filled cartridge or to load an empty cartridge with refill film or with bulk film. For further details please apply to your photo-dealer. The take-up spool of the EXAKTA Varex requires no special trimming of the film leader, you may use any of the usual trimmings on the market. When using an empty film cartridge the film tongue has to conform with the core of the spool (see Fig. 30). Loading the camera is performed as follows:

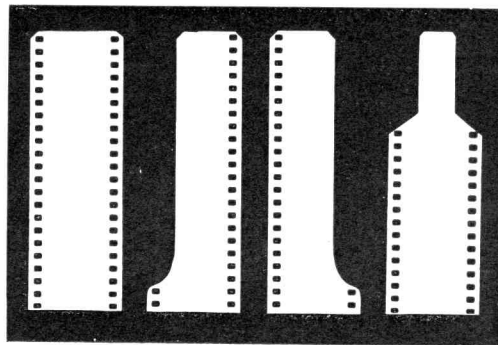

Open the camera back, as described in Section A. Pull out the film rewinding knob (37). Insert the cartridge with the unexposed film into the film chamber (39). Push back the film rewinding knob (37) into its original position, at the same time slightly turning its rim!

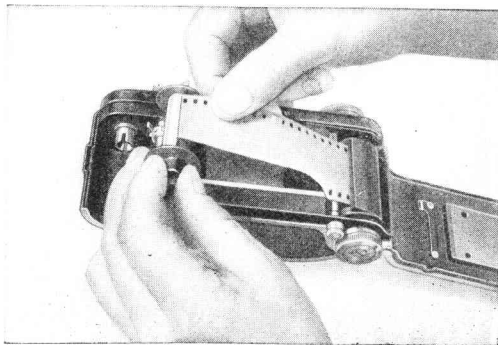
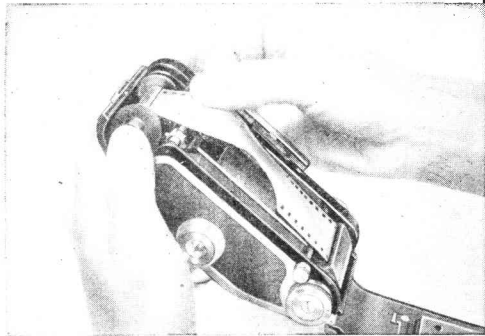
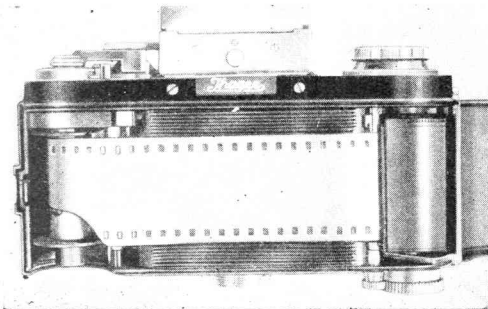

Fig. 31



Attention: On no account press the centre part (38) of the film rewinding knob, otherwise the film transport will not function. We recommend taking the receiving spool (29) out of the camera when loading. Push the film leader projecting from the cartridge under the clamp spring of the take-up spool (29) as shown in Fig. 31. Conduct the film across the film track with the two film guides (32) and replace the receiving spool into the camera, the emulsion (dull) side of the film facing the lens. Take care that the fork of the film transport lever (6) engages properly the bar in the hole of the spool.



It is also possible to fasten the film on to the receiving spool without removing the spool from the camera, whereby the clamp spring must lie upwards (s. Fig. 32).

When fastening the film to the receiving spool (29) the camera should be placed on a solid stand (do not let the camera back hang down!).

Fig. 33

Fig. 34

The film strip must run perfectly straight and flat over the film track and the film transport sprockets (31) to the receiving spool (29) (Fig. 33). Take care that the sprocket teeth engage on both sides of the film perforation. Close the camera back (40) (see Section A). When closing the camera, make sure that receiving spool and film remain in their proper position.

First, two blank exposures have to be made: Open the Finder Hood (11), as described in Section B. If there is no image visible in the Finder Hood, move the film transport lever (6) up to the stop. Release by pressing the shutter release knob (3): the first blank exposure. Wind up film transport lever (6) again as far as the stop and release again: second blank exposure. Wind up film transport lever (6) a third time as far as it will go: an unexposed section of film is now brought into position in the film gate (33) ready for the first actual exposure, and the film leader, exposed when you inserted the film, has been wound on to the receiving spool.

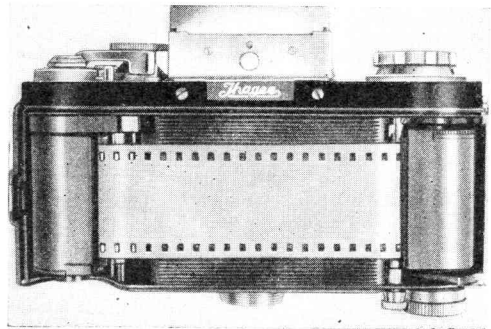
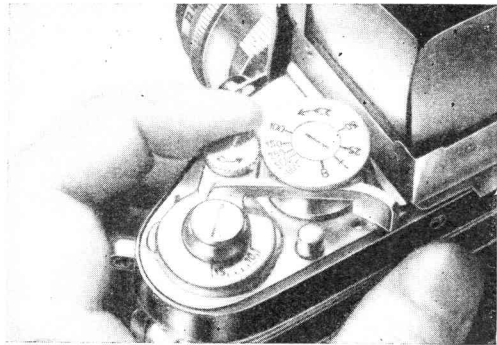

Fig. 35

Finally, set exposure counter (5): Turn the little knob (5a) of exposure counter (5) with your left index finger (see Fig. 34) in the direction of the arrow, until, one stroke before No. 1. (The mechanism stands against the counting mark, counts each picture after the exposure has been made, it points, therefore, to 1 after the first exposure). Now the camera is ready for picture taking.

If the exposed film is not to be rewound into the cartridge after the last (36th) exposure, but to be removed from the camera in a second cartridge, the procedure is exactly the same as described above. Simply remove the take-up spool (29) and replace it by an empty but unobjectionable cartridge. To load the cartridge, open it and fix the film leader to the spool (for film trimming see Fig. 30). Then insert the cartridge so that the fork of the film transport lever (6) engages the bar in the spool,

causing the film to be wound up, emulsion side inwards. Illustration 35 shows the exact path of the film.

For control of the film transport there is the control disk marked by a red cross (19): The cross rotates simultaneously with the spool core of the cartridge (Fig. 36).

To assist your memory there is, on the large speed-setting knob (17), a film speed indicator (18). On the EXAKTA Varex IIa this indicator has been adapted to suit international film gradations (Fig. 36). It should be set imme-

Fig. 36

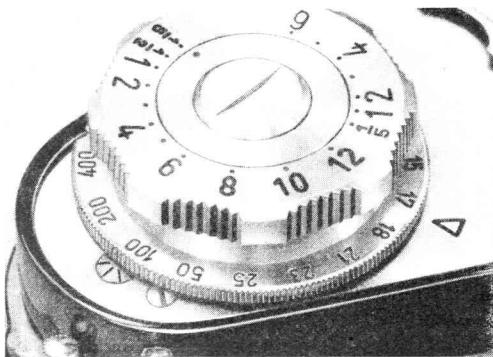

diately after film loading, being rotatable in anticlockwise direction by means of its milled edge. It is engraved with various numeral values ranging from 6 to 400 and with four alphabetical characteristics. The numerals refer to the sensitivity of black-and-white films (e. g. 17 = 17/10⁰ DIN, 100 = 100 ASA, etc.), whereas the letters have the following meaning:

- C (black) = Color reversible film for daylight
- C (red) = Color reversible film for artificial light
- NC (red) = Color negative film for artificial light
- NC (black) = Color negative film for daylight.

According to the film you have in your camera set the respective numeral or letter opposite the triangle (∇) engraved on the covering plate. You can then always see which film was placed into the camera, even in cases of longer intervals between snapshooting.

Two examples:

- Agfa Isopan ISS, 21/10⁰ DIN = the "21" of the film speed indicator stands against the triangle (∇)
- Kodachrom daylight film = the black "C" of the film speed indicator stands against the triangle (∇).

H. Changing the film

a) When using the take-up spool:

One film-length of 1,60 m (5'4") will generally take more than 36 exposures. Even if the exposure counter (5) points to "36" (one stroke before 1), one or two more exposures are possible, until the film transport lever (6) cannot be wound any more. Here, it may happen that the lever (6) cannot be moved as far as the stop. In this case the rewinding stud (7) has to be depressed and the film transport lever (6) advanced as far as it will go. The lever (6) can now return into its original position, and

Fig. 37

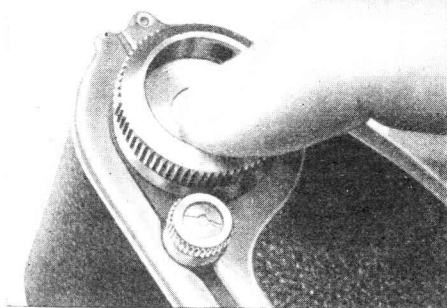

the stud (7) automatically springs up again as soon as the pressure ceases.

Film rewinding is performed as follows: Hold the camera with your left hand and press down the stud (7) during the whole rewinding process. With your right index finger, press in the centre part (38) of the film rewinding knob (37) as far as it will go (Fig. 37). Now the fork of the film rewinding knob catches the bar of the film spool, and by even rotation of the rewinding knob (Fig. 38) the film is rewound into the original cartridge. A sure sign that the film is being rewound correctly is the rotating of the control disk (19) and of the axle of the receiving spool, around which the film transport lever (6) swings (Fig. 39). During the rewind operation, the axle of the receiving spool, with the big screw slit, rotates in the opposite direction of the movement of the film transport lever (6). Once the film is rewound, the rewinding axle no longer rotates. As soon as the stud (7) has sprung back to its neutral position, the



Fig. 38

Fig. 39

film can be wound as usual. Now open the EXAKTA Varex (see Section A) and, after having drawn out the film rewinding knob (37), remove the cartridge containing the exposed film (see Fig. 40). Press the exterior ring of the rewinding knob (37) against the camera.

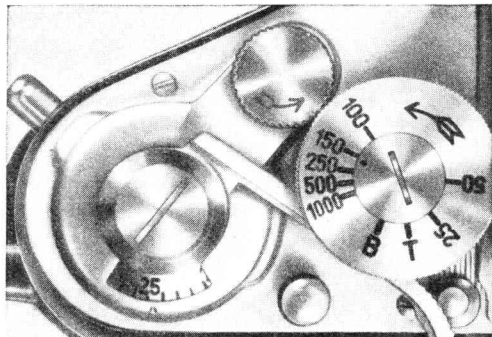

b) When using a take-up cartridge: If the exposed film is wound into a cartridge instead of on to the take-up spool, rewinding is not necessary. As soon as the film is used up (film transport lever <6> can no longer be wound up), the film is cut off with the built-in knife (34). Loosen the knife release (35) by turning it to the left. It is fastened on one end of a thin bar, on the other end of which is the cutting knife (34). If you draw out the knife release (35) from the camera body (about 4 cm) (Fig. 41), the film-cutter (34) crosses the film-track and cuts off the film-strip. This done, move the knob (35) into the camera again and screw it tight by turning it to the right. By two

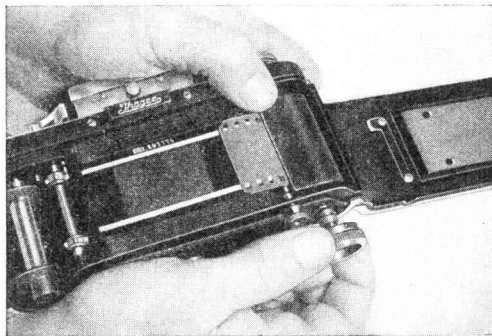

Fig. 40

blank exposures the film end will be drawn into the cartridge, so that the last exposure is sheltered from light. Now open the camera as described before and remove the cartridge containing the exposed film.

Operate in the same way, if any single part of the film, e. g. after the 10th, 15th, or 20th exposure, is to be removed from the EXAKTA Varex for processing. You must, of course, insert the unexposed section of the film-strip again (fasten the beginning either to the take-up spool or into a take-up cartridge). When cutting off film parts from a take-up spool in your camera, you must, of course, go into the darkroom, in order to remove the exposed part of the film.

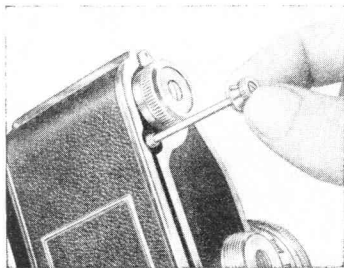

Fig. 41

Being precision-built, as already mentioned, the EXAKTA Varex requires good care besides correct handling, which, needless to say, refers also to the accessories. All essential facts regarding this point are given in Section L, page 59! Every owner of an EXAKTA Varex should follow these rules carefully.